

DEPENDABLE

BEING **DEPENDABLE** IS MORE THAN A POSITIVE TRAIT. TO MANY OF OUR CUSTOMERS IT IS A CONSTANT STATE OF AWARENESS THAT EMPOWERS THEM TO ANTICIPATE, PREVENT, MITIGATE OR REACT IN A FLUID SITUATION.

OUR WORK HERE AT PELICAN IS NOT VERY DIFFERENT. WE DO HAVE AN IMPORTANT JOB: MANUFACTURING THE BEST PROTECTOR™ CASES AND LIGHTING TOOLS THE WORLD HAS EVER SEEN. BECAUSE IN THE END, OUR PRODUCTS HAVE TO BE AS DEPENDABLE AS THE PEOPLE WHO USE THEM.



> ULTIMATE EQUIPMENT PROTECTION FROM THE ELEMENTS.



EXTRA PROTECTION

Pelican's Pick 'N' Pluck™ foam lets you customize the interior according to your gear. An easy, do-it-yourself system for custom-shaping the interior of the case according to your equipment. Layers of foam are pre-scored in tiny cubes. Simply measure your equipment over the grid and pluck away. Contents stay in place and get extra protection at the same time.



All Protector™ Cases come standard with Pick 'N' Pluck™ foam.

EASY RIDING

Stainless steel ball bearing wheels (on select cases) last longer and ride smoother. The nylon hub adjacent to the stainless steel is made to resist heat. Result: less wear and tear on the polyurethane wheel.



NYLON HUB
STAINLESS STEEL BALL BEARING WHEELS
POLYURETHANE TIRE

KEEP IT SHUT

Metal reinforced padlock protectors provide added strength and extra security against cutting and theft.



CUSTOMIZE IT

Customize your case to hold electronic interface panels, or create the perfect protection insert for your equipment. Close the lid and see your logo applied as a decal or hot stamp (call for details).



Panel frame mounting system



Extra protection



Custom logos

STRONGER BY DESIGN

The Pelican Protector™ Case uses an open cell core and solid wall construction, which is actually stronger and lighter than a solid core wall. Travel light with heavy protection. And you know it's a Pelican™ Case by the distinctive dual band top surface. Stainless steel pins are used for hinges and handles. The new Double-Throw latches are smarter and easier to open: it's the classic 'C' clamp design with a secondary movement that works like a pry bar to start the release and offers plenty of leverage to open with a light pull.



New Stronger Double-Throw Latch



WATERTIGHT

The secret is the tongue-and-groove fit with Polymer o-ring acting as a waterproof seal. Also, the new Automatic Pressure Equalization Valve releases built-up air pressure while keeping water molecules out, resulting in a watertight case that is even easier to open.



> MEET THE OTHER HALF OF PELICAN

The same durability and ingenuity built into every Pelican case also sets our flashlights apart. We're illuminating the world's darkest and most dangerous places with specialized lighting tools:

- Safety approved lights for hazardous areas
- Tactical lights for military and law enforcement
- Specialized lights for fire and rescue operations
- Submersible lights for diving

FOR THE FULL LINE OF PELICAN PROFESSIONAL LIGHTING TOOLS GO TO WWW.PELICAN.COM

PELICAN LIFETIME GUARANTEE

Pelican guarantees its products for a lifetime against breakage or defects in workmanship. Pelican cases are guaranteed to be watertight to a depth of 3 feet for 30 minutes (IP 67) unless otherwise stated if properly closed with undamaged o-ring in place. Pelican's liability is limited to the case and not its contents. This guarantee does not cover the lamp or batteries (rechargeable or alkaline) for lights. Any liability, either expressed or implied, is limited to replacement of the product. This guarantee is void if the Pelican™ product has been abused beyond normal and sensible wear and tear. This guarantee does not cover shark bite, bear attack or damage caused by children under five.

U.S.A. & GLOBAL HEADQUARTERS

23215 Early Avenue
Torrance, CA 90505 USA
Tel 310.326.4700
800.473.5422 (Outside CA)
Fax 310.326.3311
www.pelican.com

CANADA

Pelican Products, Inc.
10221-184th St.
Edmonton, Alberta
T5S 2J4 Canada
Tel 780.481.6076
Fax 780.481.9586
www.pelican.ca

EUROPE, MIDDLE EAST & AFRICA

Peli Products, S.A.
c/ Casp, 33-B Pral.
08010 - Barcelona, Spain
Tel +34 934 674 999
Fax +34 934 877 393
www.peli.com

JAPAN

Pelican Products K.K.
Suntec Bldg. 7F
2-2-7 Honcho, Funabashi-shi
Chiba 273-0005 Japan
Tel +81(0)47.433.7715
Fax +81(0)47.433.7882
www.pelicanproducts.jp

AUSTRALIA

Pelican Products Australia P/L
Unit 3
65-67 Nelson St.
Stepney, South Australia 5069
Tel: (08) 8362-6161
Fax: (08) 8362-9326
www.pelicanaustralia.com

CHINA

Pelican Products China
Pine City Building
Room 1026
777 Zhaoliabang Road
Shanghai, China 200032
Tel +86.21.64189685
Fax +86.21.64189679

DISTRIBUTED BY:



©2008 Pelican Products, Inc. All trademarks and logos displayed herein are registered and unregistered trademarks of Pelican Products, Inc. and others. iPod, iPod Mini, Shuffle, and Nano is a registered trademark of Apple Computer
Part. No. 0030-000-600 0C/08

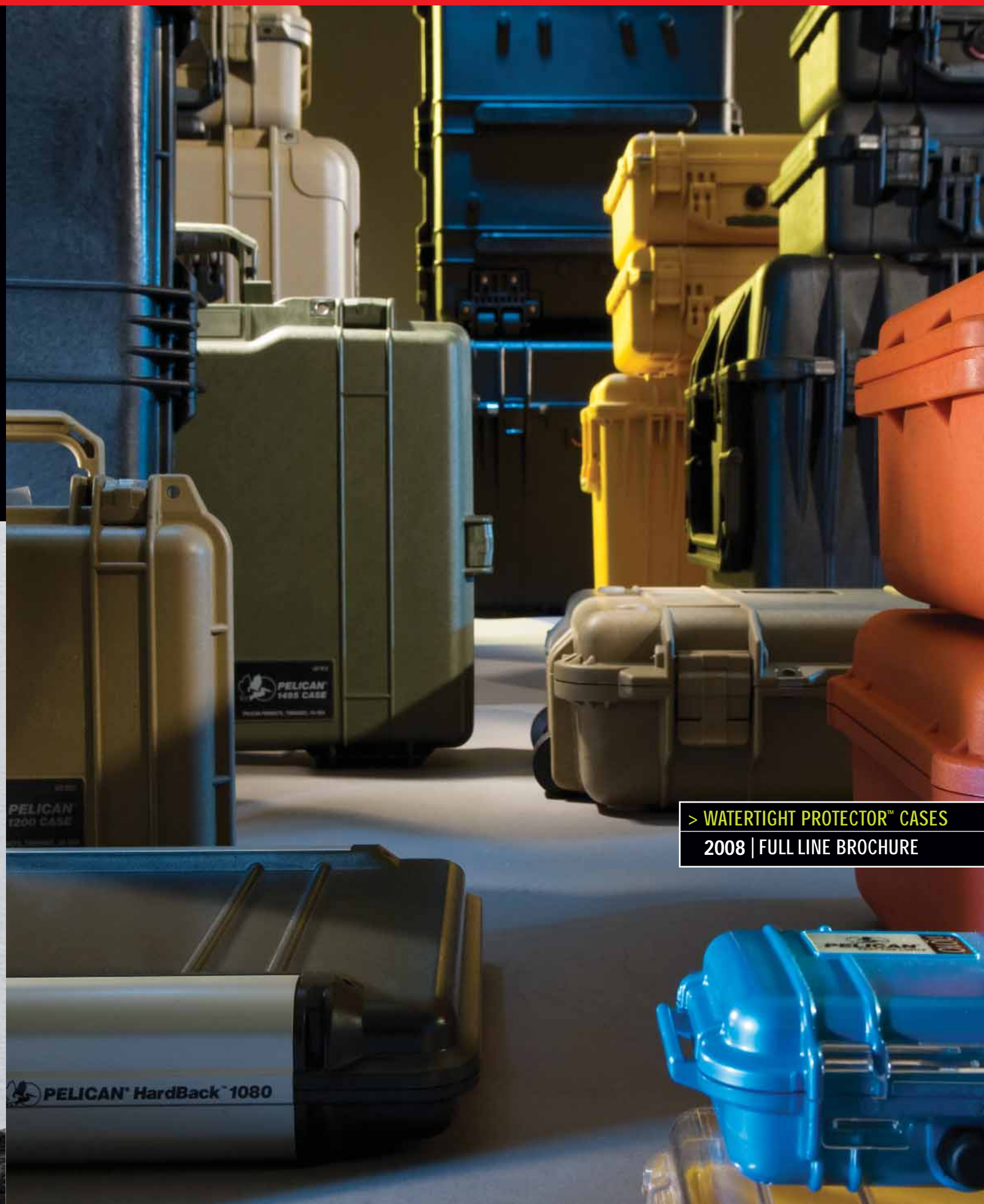

> WATERTIGHT PROTECTOR™ CASES
2008 | FULL LINE BROCHURE

> MEMORY CARD CASE |



CAT. NO. 0910
 ■ Stores 8 SD cards and 16 mini SD cards

CAT. NO. 0920
 ■ Stores 16 XD cards

CAT. NO. 0930
 ■ Stores 16 Memory sticks

CAT. NO. 0940
 ■ Stores 4 compact flash cards

Water resistant case stores and protects memory cards.

> MICRO CASE SERIES™ |



Protect your player while using it via the external headphone jack

All Micro Cases come standard with rubber liner. Pick 'N' Pluck™ Foam inserts are available.

> SMALL CASES |



> LAPTOP CASES |



Double safety locking latches with keys for 1470 and 1490 cases

CAT. NO. 1080CC
 ■ Computer case liner

CAT. NO. 1090CC
 ■ Computer case liner

CAT. NO. 1490CC#1
 ■ Lid organizer, fitted shock absorbing tray, and removable shoulder strap (shown)

CAT. NO. 1490CC#2
 ■ Pick 'N' Pluck™ foam, lid organizer and removable shoulder strap

CAT. NO. 1495 CC#1
 ■ Lid organizer, shock absorbing tray, nylon padded computer sleeve, accessories pouch, and removable shoulder strap

CAT. NO. 1495 CC#2
 ■ Pick 'N' Pluck™ foam, lid organizer and removable strap

CAT. NO. 1434
 ■ Case with padded dividers and lid organizer

CAT. NO. 1437
 ■ Case with Padded Office Divider Set and Lid Organizer (shown)

CAT. NO. 1444
 ■ Case with utility padded divider set and lid organizer

CAT. NO. 1447
 ■ Case with Padded Office Divider Set and Lid Organizer

> MEDIUM CASES |



CAT. NO. 1500EMS
 ■ Custom configured lid organizer and trays for EMS professionals. Available in 3 sizes: 1500, 1550, and 1600 Cases.

CAT. NO. 1510LOC (Laptop Overnight Case)
 ■ Fully enclosed apparel insert, padded laptop sleeve, and accessory pouch

■ 1510 also available in standard configurations: foam, no foam, padded dividers

> MEDIUM CASES |



CAT. NO. 1550EMS
 ■ EMS configuration available

CAT. NO. 1564
 ■ 1560 case with padded dividers

> LARGE CASES |



CAT. NO. 1600EMS
 ■ EMS configuration available

CAT. NO. 1624
 ■ 1620 case with padded dividers

> LARGE CASES |



■ 50/50 lid-to-base ratio for easy loading

■ Completely detachable lid for full access

CAT. NO. 0357 (For 0350 and 0370 Cases)
 ■ Four removable casters, mounting plates and pull strap with nylon carry bag

> LONG CASES |



CAT. NO. 1780W
 ■ Case with Rifle Hard Liner Insert

CAT. NO. 1780WRF
 ■ Case with Rifle Foam Cut Insert

■ Humidity gauge changes color above 40%

■ Automatic mil-spec Equalization Valve

■ 50/50 lid-to-base ratio for easy loading

■ Completely detachable lid for full access

> CASE SPECIFICATIONS AND FEATURES

CAT. NO.	INTERIOR	EXTERIOR	PADDED DIVIDERS	RUBBERIZED HANDLES	PANEL FRAMES	PERSONALIZED NAMEPLATE	LID ORGANIZER	WHEELS	COLORS
MCC	4.20 x 2.30 x 0.56 (10.7 x 5.8 x 1.4 cm)	5.00 x 3.30 x 0.95 (12.7 x 8.4 x 2.4 cm)							■
1010	4.37 x 2.87 x 1.68 (11.1 x 7.3 x 4.3 cm)	5.43 x 4.06 x 2.12 (13.8 x 10.3 x 5.4 cm)							■ ■ ■ ■
1020	5.31 x 3.56 x 1.68 (13.5 x 9 x 4.3 cm)	6.37 x 4.75 x 2.12 (16.2 x 12.1 x 5.4 cm)							■ ■ ■ ■
1030	6.37 x 2.62 x 2.06 (16.2 x 6.7 x 5.2 cm)	7.50 x 3.87 x 2.43 (19 x 9.8 x 6.2 cm)							■ ■ ■ ■
1040	6.50 x 3.87 x 1.75 (16.5 x 9.8 x 4.4 cm)	7.50 x 5.06 x 2.12 (19 x 12.8 x 5.4 cm)							■ ■ ■ ■
1050	6.31 x 3.68 x 2.75 (16 x 9.3 x 7 cm)	7.50 x 5.06 x 3.12 (19 x 12.8 x 7.9 cm)							■ ■ ■ ■
1060	8.25 x 4.25 x 2.25 (20.9 x 10.8 x 5.7 cm)	9.37 x 5.56 x 2.62 (23.8 x 14.1 x 6.7 cm)							■ ■ ■ ■
i1010	4.37 x 2.87 x 1.68 (11.1 x 7.3 x 4.3 cm)	5.43 x 4.06 x 2.12 (13.8 x 10.3 x 5.4 cm)							■ ■ ■ ■ ■ ■ ■ ■
i1030	6.37 x 2.62 x 2.06 (16.2 x 6.7 x 5.2 cm)	7.50 x 3.87 x 2.43 (19 x 9.8 x 6.2 cm)							■ ■ ■ ■ ■ ■ ■ ■
1120	7.25 x 4.75 x 3.06 (18.4 x 12.1 x 7.8 cm)	8.12 x 6.56 x 3.56 (20.6 x 16.7 x 9 cm)			0				■ ■ ■ ■ ■ ■ ■ ■ ■ ■
1150	8.18 x 5.68 x 3.62 (20.8 x 14.4 x 9.2 cm)	9.12 x 7.56 x 4.37 (23.2 x 19.2 x 11.1 cm)			0				■ ■ ■ ■ ■ ■ ■ ■ ■ ■
1200	9.25 x 7.12 x 4.12 (23.5 x 18.1 x 10.5 cm)	10.62 x 9.68 x 4.87 (27 x 24.6 x 12.4 cm)			0				■ ■ ■ ■ ■ ■ ■ ■ ■ ■
1300	9.87x 7.00 x 6.12 (25.1 x 17.8 x 15.5 cm)	10.62 x 9.68 x 6.87 (27 x 24.6 x 17.4 cm)			0				■ ■ ■ ■ ■ ■ ■ ■ ■ ■
1400	11.81 x 8.87 x 5.18 (30 x 22.5 x 13.2 cm)	13.37 x 11.62 x 6.00 (33.9 x 29.5 x 15.2 cm)			0	0			■ ■ ■ ■ ■ ■ ■ ■ ■ ■
1080	12.80 x 9.80 x 1.70 (32.5 x 24.9 x 4.3 cm)	13.75 x 10.95 x 2.55 (34.9 x 27.8 x 6.5 cm)							■ ■ ■ ■
1090	15.00 x 11.32 x 1.92 (38.1 x 28.7 x 4.9 cm)	15.83 x 13.10 x 2.86 (40.2 x 33.3 x 7.3 cm)							■ ■ ■ ■
1430	13.56 x 5.76 x 11.70 (34.4 x 14.6 x 29.7 cm)	16.93 x 9.61x 13.42 (43 x 24.4 x 34.1 cm)	0	S	0	0	0		■ ■ ■ ■ ■ ■ ■ ■ ■ ■
1440	17.10 x 7.50 x 16.00 (43.4 x 19 x 40.6 cm)	19.70 x 12.00 x 18.00 (50 x 30.5 x 45.7 cm)	0	S	0	0	0	S	■ ■ ■ ■ ■ ■ ■ ■ ■ ■
1470	15.62 x 10.43 x 3.75 (39.7 x 26.5 x 9.5 cm)	16.68 x 13.06 x 4.37 (42.4 x 33.2 x 11.1 cm)		S	0	0			■ ■ ■ ■
1490	17.75 x 11.37 x 4.12 (45.1 x 28.9 x 10.5 cm)	19.87 x 13.93 x 4.68 (50.4 x 35.4 x 11.9 cm)		S	0	0	0		■ ■ ■ ■
1495	18.87 x 13.12 x 3.81 (47.9 x 33.3 x 9.7 cm)	21.62 x 17.25 x 4.87 (54.9 x 43.8 x 12.4 cm)		S		0	0		■ ■ ■ ■
1450	14.62 x 10.18 x 6.00 (37.1 x 25.8 x 15.2 cm)	16.00 x 13.00 x 6.87 (40.6 x 33 x 17.4 cm)	0	S	0	0			■ ■ ■ ■ ■ ■ ■ ■ ■ ■
1500	16.75 x 11.18 x 6.12 (42.5 x 28.4 x 15.5 cm)	18.50 x 14.06 x 6.93 (47 x 35.7 x 17.6 cm)	0	S	0	0	0		■ ■ ■ ■ ■ ■ ■ ■ ■ ■
1510	19.75 x 11.00 x 7.60 (50.1 x 27.9 x 19.3 cm)	22.00 x 13.81 x 9.00 (55.9 x 35.1 x 22.9 cm)	0	S	0	0	0	S	■ ■ ■ ■ ■ ■ ■ ■ ■ ■
1520	17.87 x 12.75 x 6.75 (45.4 x 32.4 x 17.1 cm)	19.12 x 15.43 x 7.56 (48.5 x 39.2 x 19.2 cm)	0	S	0	0	0		■ ■ ■ ■ ■ ■ ■ ■ ■ ■
1550	18.43 x 14.00 x 7.62 (46.8 x 35.5 x 19.3 cm)	20.62 x 16.87 x 8.12 (52.4 x 42.8 x 20.6 cm)	0	S	0	0			■ ■ ■ ■ ■ ■ ■ ■ ■ ■
1560	20.37 x 15.43 x 9.00 (51.7 x 39.2 x 22.9 cm)	22.06 x 17.93 x 10.43 (56 x 45.5 x 26.5 cm)	0	S		0	0	S	■ ■ ■ ■ ■ ■ ■ ■ ■ ■
1600	21.43 x 16.50 x 7.87 (54.4 x 41.9 x 20 cm)	24.25 x 19.43 x 8.68 (61.6 x 49.3 x 22 cm)	0	S		0	0		■ ■ ■ ■ ■ ■ ■ ■ ■ ■
1610	21.68 x 16.62 x 10.56 (55 x 42.2 x 26.8 cm)	24.71 x 19.58 x 11.93 (62.7 x 49.7 x 30.3 cm)	0			0	0	S	■ ■ ■ ■ ■ ■ ■ ■ ■ ■
1620	21.37 x 16.31 x 12.56 (54.3 x 41.4 x 31.9 cm)	24.81 x 19.37 x 13.87 (63 x 49.2 x 35.2 cm)	0			0	0	S	■ ■ ■ ■ ■ ■ ■ ■ ■ ■
1630	27.70 x 20.98 x 15.50 (70.3 x 53.3 x 39.4 cm)	31.28 x 24.21 x 17.48 (79.4 x 61.5 x 44.4 cm)	0			0	0	S	■ ■ ■ ■ ■ ■ ■ ■ ■ ■
1640	23.70 x 24.00 x 13.90 (60.2 x 60.9 x 35.3 cm)	27.20 x 27.50 x 16.30 (69.1 x 69.8 x 41.4 cm)	0			0	0	S	■ ■ ■ ■ ■ ■ ■ ■ ■ ■
1650	28.50 x 17.37 x 10.50 (72.4 x 44.1 x 26.7 cm)	30.75 x 20.50x 11.62 (78.1 x 52 x 29.5 cm)	0			0	0	S	■ ■ ■ ■ ■ ■ ■ ■ ■ ■
1660	28.18 x 19.75 x 17.62 (71.5 x 50.1 x 44.7 cm)	31.50 x 22.87 x 19.00 (80 x 58.1 x 48.2 cm)	0			0	0	S	■ ■ ■ ■ ■ ■ ■ ■ ■ ■
1690	30.01 x 25.02 x 16.01 (76.2 x 63.5 x 40.6 cm)	33.36 x 28.44 x 18.23 (84.7 x 72.2 x 46.3 cm)	0			0		S	■ ■ ■ ■ ■ ■ ■ ■ ■ ■
0340	18.00 x 18.00 x 18.00 (45.7 x 45.7 x 45.7 cm)	20.50x 20.50x 19.25 (52 x 52 x 48.9 cm)	0			0	0	S	■ ■ ■ ■ ■ ■ ■ ■ ■ ■
0350	20.00 x 20.00 x 20.00 (50.8 x 50.8 x 50.8 cm)	22.50 x 22.43 x 21.25 (57 x 57 x 53.5 cm)	0			0	0	0	■ ■ ■ ■ ■ ■ ■ ■ ■ ■
0370	24.00 x 24.00 x 24.00 (60.9 x 60.9 x 60.9 cm)	26.50 x 26.50 x 25.25 (67.3 x 67.3 x 64.1 cm)	0			0	0	0	■ ■ ■ ■ ■ ■ ■ ■ ■ ■
0500	34.95 x 18.45 x 25.25 (88.7 x 46.8 x 64.1 cm)	39.95 x 23.45 x 28.65 (101.4 x 59.5 x 72.7 cm)				0		0	■ ■ ■ ■ ■ ■ ■ ■ ■ ■
1700	35.75 x 13.50 x 5.25 (90.8 x 34.3 x 13.3 cm)	38.12 x 16.00 x 6.12 (96.8 x 40.6 x 15.5 cm)				0		S	■ ■ ■ ■ ■ ■ ■ ■ ■ ■
1720	42.00 x 13.50 x 5.25 (106.6 x 34.3 x 13.3 cm)	44.37 x 16.00 x 6.12 (112.7 x 40.6 x 15.5 cm)				0		S	■ ■ ■ ■ ■ ■ ■ ■ ■ ■
1750	50.50 x 13.50 x 5.25 (128.2 x 34.3 x 13.3 cm)	53.00 x 16.00 x 6.12 (134.6 x 40.6 x 15.5 cm)				0		S	■ ■ ■ ■ ■ ■ ■ ■ ■ ■
1730	34.00 x 24.00 x 12.50 (86.3 x 60.9 x 31.7 cm)	37.05 x 27.20 x 14.37 (94.1 x 69.1 x 36.5 cm)				0		S	■ ■ ■ ■ ■ ■ ■ ■ ■ ■
1780	42.00 x 22.00 x 15.10 (106.6 x 55.9 x 38.3 cm)	44.90 x 25.32 x 16.50 (114 x 64.3 x 41.9 cm)				0		S	■ ■ ■ ■ ■ ■ ■ ■ ■ ■

MICRO CASES:
 All Micro Cases are available in solid colors: Black, Blue, Yellow and Red; or clear with colored liners. 11010 available in white, black, yellow and IP-OD blue, green, silver and pink. 11030 available in white and yellow only.

PROTECTOR™ CASES:
 Pick 'N' Pluck™ foam - All Protector™ Cases come standard with Pick 'N' Pluck™ foam except 1780W and 1780WRF case. To order Protector™ Cases without foam add NF to the end of the catalog number.

50/50 lid-to-base ratio for easy loading

Completely detachable lid for full access

Humidity gauge changes color above 40%

Automatic mil-spec Equalization Valve

Standard feature

Optional Accessory

OD Green available upon request

Protector™ Case Colors Available

BLACK SILVER YELLOW
 ORANGE BLUE OD GREEN DESERT TAN

*Case contents not included